



Description and Benefits:

The **WB** is a small, lightweight device that activates and illuminates when water is sensed. Simply place on a flat surface under your equipment or attach using the included mounting brackets. The **WB** relies on the electrical conductivity of water to change the resistance across two contacts at the base of the enclosure. When the contacts are bridged by water, the resistance changes and triggers an alarm.

Choose either the **WBWO-1** or the **WBWA-1** model for applications that require visual alert and/or relay contacts. Both units require an external 24VAC/VDC power supply. The **WBWA-1** unit will trigger both visual and audible alarms when water is sensed.

Features:

- ◇ Visual and audible alarm
- ◇ Small, compact design
- ◇ DPDT relay
- ◇ Compact size
- ◇ Removable mounting bracket

Specifications:

Switch Type:	DPDT relay
Electrical Rating:	DPDT 1 A @ 24 VAC/DC, 1 A @ 120 VAC
Power Requirements:	11-27 VAC/DC
Power Consumption:	DC 25 mA typical and 75 mA max, AC 30 mA typical and 85 mA max
Electrical Connections:	attached 22 AWG, PVC insulated cable (4.8 ft long)
Enclosure:	acrylic, ABS plastic
Temperature Limits:	32 to 122°F (0 to 50°C)
Weight:	4.3 oz
Dimensions:	3" L x 2" W x 1-1/4" H

Typical Uses:

- Dishwashers
- Sinks
- Toilets
- Washing machines
- Water heaters
- Air conditioners

Wiring:

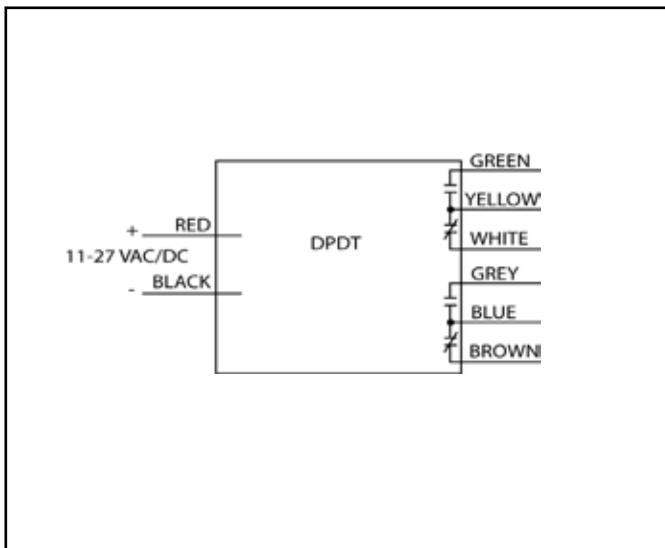

Ordering Information:

PART NUMBER

- WBWO-1 Sensor with Relay, 24 VAC/DC power
- WBWA-1 Sensor with Relay, 24 VAC/DC power with audible alarm